

Multi-Basket Duplex Strainer

Model 570

Pipeline
Strainer

Cast
Construction

Permanent
Media

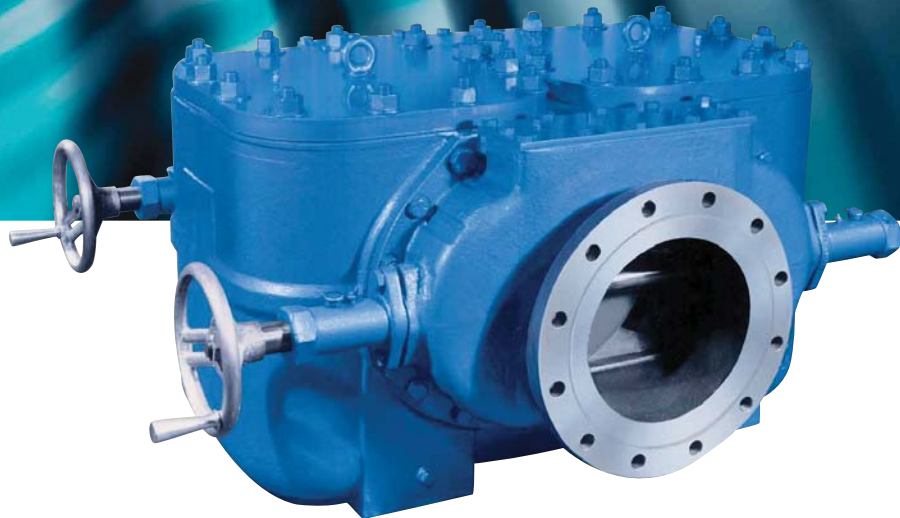

- 8" to 24"
- Iron or Carbon Steel
- Flanged

FEATURES

- Continuous flow—no shutdown for basket cleaning
- Sliding gate design
- Eight baskets per strainer (four per side)
- Bolted cover
- Compact
- Threaded drain
- Perforated or mesh stainless steel baskets standard
- Synchronized chain drive
- Pressure equalization assembly

OPTIONS

- Stainless steel construction
- Basket perforations from 1/32" to 1/2"
- Basket mesh of 20, 40, or 60
- Monel baskets
- Drain valves
- Cover lift davit
- Pressure differential gauge and switch connections
- Basket flange gaskets
- Magnetic basket inserts
- Left hand drive

Continuous Operation While Straining up to 30,000 GPM

The Eaton Model 570 duplex basket strainer, specifically designed to remove potential damage causing particles from large volumes of water and other process media, strains up to 30,000 gpm efficiently and cost effectively. The strainer operates continuously, and the pipeline flow never has to shut down for strainer basket cleaning.

A sliding gate mechanism operated by hand wheels, switches the flow from one basket chamber to the other. The free-floating valve disc mechanism moves easily and does not bind. The fully enclosed, valve-operating stem protects it from the fluid flow.

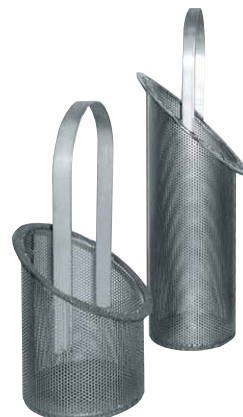

Multi-basket Strainer

The Model 570 contains four baskets in each of the two straining chambers for a total of eight per duplex strainer. It is a very compact unit for its size with a low profile—ideal for tight installations in which space is a problem. Because of the multi-basket design, the individual baskets are smaller and lighter than would be possible with just one basket. One person can easily and rapidly remove and clean the baskets without lifting tackle.

The baskets feature a unique, angled top to permit direct fluid entry that contributes to the strainer's low-pressure drop. Because of the large open area ratio in the baskets, they have an unusually high dirt holding capacity, which results in a longer cycle between basket cleaning. Over time, the savings in labor and downtime for basket cleaning will be considerable.

EATON

Powering Business Worldwide

MODEL 570 Multi-Basket Duplex Strainer

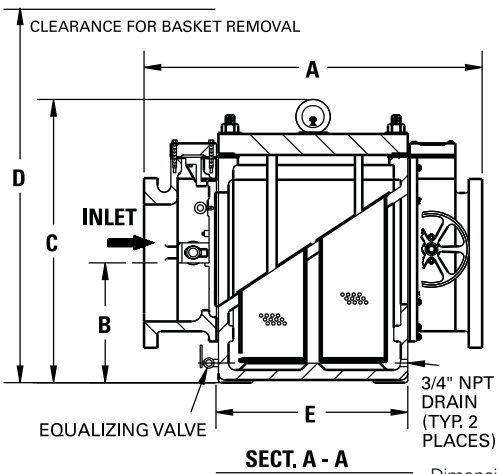
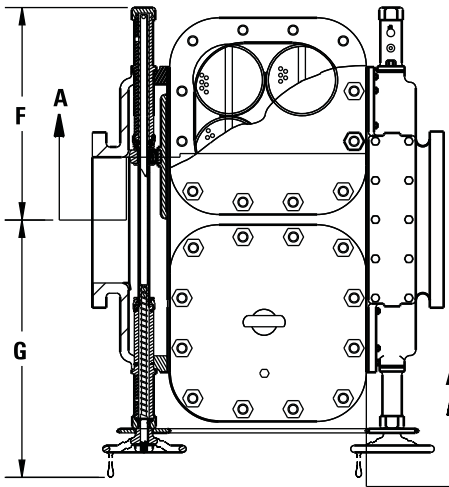

Dimensions and weights are for reference only. Contact Eaton for certified drawings

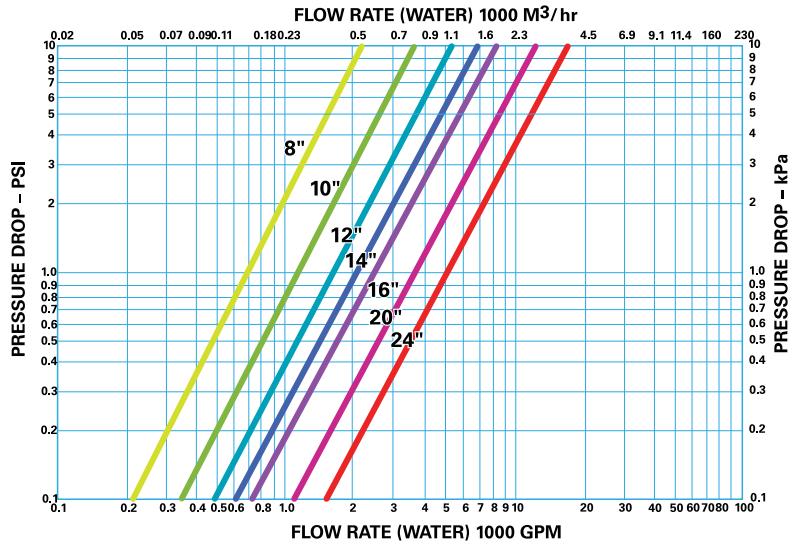

Selection Chart

Size	Material	End Connection	Gaskets	Pressure Rating
8" to 24"	Iron	Flanged 125#	Non-Asbestos	125 psi @ 100 °F
8" to 24"	Carbon Steel	Flanged 150#	Non-Asbestos	175 psi @ 100 °F
8" to 16"	Carbon Steel	Flanged 300#	Non-Asbestos	300 psi @ 100 °F

DIN flanges available

C_y Factors*

Size	Value	Size	Value
8"	700	16"	2500
10"	1250	20"	3600
12"	1600	24"	5200
14"	2000		

* For water with clean, perforated basket

Dimensions (in/mm)

Pipe Size	A	B	C	D	E	F	G	Weight-Iron (lb / kg)	Weight-Carbon Steel (lb / kg)
8	38.50 / 978	8.25 / 210	20.50 / 521	38.00 / 965	18.25 / 464	18.00 / 457	28.50 / 724	1410 / 641	1565 / 711
10	40.50 / 1029	10/38 / 264	23.75 / 603	44.00 / 1118	20.50 / 521	20.25 / 514	30.50 / 775	1880 / 855	2087 / 949
12	43.50 / 1105	13.50 / 343	29.25 / 743	52.00 / 1321	23.00 / 584	23.38 / 594	32.50 / 826	2604 / 1184	2890 / 1314
14	46.25 / 1175	15.75 / 400	31.63 / 803	60.00 / 1524	24.88 / 632	25.56 / 649	35.00 / 889	3006 / 1366	3337 / 1517
16	49.63 / 1261	17.81 / 458	35.00 / 889	66.00 / 1676	28.13 / 715	27.75 / 705	37.50 / 953	4350 / 1977	4826 / 2197
20	64.00 / 1626	26.63 / 676	45.75 / 1162	88.00 / 2235	33.75 / 857	34.00 / 864	43.75 / 1111	10000 / 4545	11100 / 5045
24	67.75 / 1721	29.50 / 749	53.00 / 1346	98.00 / 2489	36.63 / 930	40.38 / 1026	49.50 / 1257	11440 / 5200	12698 / 5772

Eaton North America – HQ
44 Apple Street,
Tinton Falls, NJ 07724
Toll Free: 800 656-3344
(North America only)

Voice: +1 732 212-4700
Fax: 952 906-3706

Eaton Brazil
Voice: +55 11 2465 8822

Eaton China
Voice: +86-21 5200 0422

Eaton Europe/Africa/Middle East
Voice: +49-2486-809-0

Eaton Singapore
Voice: +65 6825 1668

©2013 Eaton Corporation. All Rights Reserved. All trademarks and registered trademarks are the property of their respective owners. Litho USA. All information and recommendations appearing in this brochure concerning the use of products described herein are based on tests believed to be reliable. However, it is the user's responsibility to determine the suitability for his own use of such products. Since the actual use by others is beyond our control, no guarantee, expressed or implied, is made by Eaton as to the effects of such use or the results to be obtained. Eaton assumes no liability arising out of the use by others of such products. Nor is the information herein to be construed as absolutely complete, since additional information may be necessary or desirable when particular or exceptional conditions or circumstances exist or because of applicable laws or government regulations.

For more information, e-mail us at filtration@eaton.com

Visit us online at eaton.com/filtration for a complete list of Eaton's filtration products.