

# Model 72L



- Carbon Steel with Tefzel® Liner
- Corrosion Resistant
- Sizes 1" to 6"
- Flanged

## FEATURES

- Excellent corrosion resistance
- Abrasion resistant 1/8" Tefzel lining
- Tefzel-coated baskets
- Service temperatures to 300 °F
- Quick opening covers
- Large capacity baskets
- Flanged drain
- Low cost alternative to exotic alloy strainers

## OPTIONS

- Monel baskets
- Hastelloy C baskets
- Consult factory for available perf and mesh sizes

A continuous lining of advanced fluoropolymer resin makes the Model 72L simplex strainer an excellent low cost alternative to exotic alloy strainers in a wide variety of corrosive or abrasive lined piping applications. These applications include wastewater treatment, paper mills, hazardous materials, flue gas systems, ultra pure water handling, chemical, and petrochemical processing. The basic design of the Model 72L is Eaton's time tested Model 72 simplex basket strainer.

The body and cover of the Model 72L are lined, not just coated with Tefzel, a registered trademark of DuPont™. This protects all wetted surfaces of the strainer, making it impervious to attack by chemicals that can cause rapid deterioration of other types of plastics and all but the most costly metal alloys.

The Tefzel fluoropolymer lining is inert to strong mineral acids, inorganic bases, halogens, and metal salt solutions. Even carboxylic acids, anhydrides, aromatic and aliphatic hydrocarbons, alcohols, aldehydes, ketones, ethers, esters, chlorocarbons, and classic polymer solvents have little effect on the Tefzel lining. Service temperatures can range up to 300 °F in many applications. The lining also displays excellent mechanical strength when handling abrasive slurries.

Fitted with fluoropolymer coated perforated baskets or mesh baskets made of Monel or Hastelloy C, these strainers can be used in almost any lined piping or similar corrosive/abrasive strainer application.



Powering Business Worldwide

# MODEL 72L Tefzel-Lined Basket Strainer

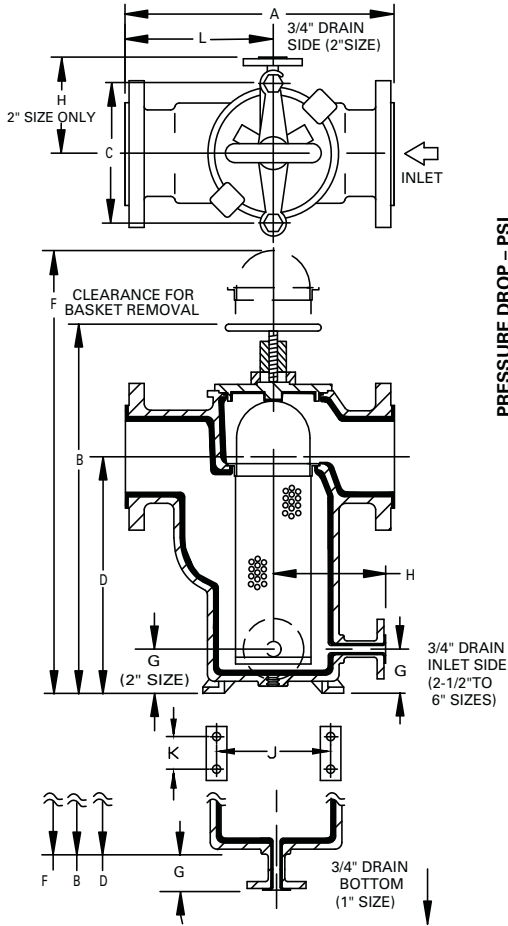

Dimensions and weights are for reference only. Contact Eaton for certified drawings.

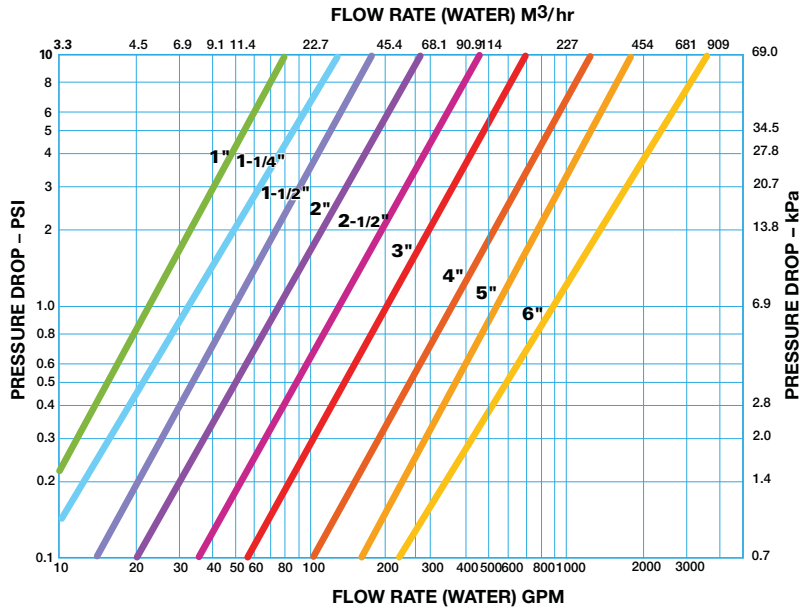

### Selection Chart

Size	Material	End Connections	Seals	Pressure Rating
1" to 6"	Carbon Steel with Tefzel® Liner	Flanged 150#	Viton®	200 psi @ 100 °F

### Dimensions (in/mm)

Pipe Size	A	B	C	D	F	G	H	J	K	L	Dry Wt (lb / kg)
1	7.88 / 200	9.00 / 229	4.00 / 102	5.00 / 127	12 / 305	2.75 / 70	-	-	-	4.50 / 114	15 / 7
2	10.75 / 273	13.75 / 349	6.75 / 172	7.63 / 194	20 / 508	1.88 / 48	5.63 / 143	5.50 / 140	2.50 / 64	5.88 / 149	48 / 22
2-1/2	11.88 / 302	15.75 / 400	8.00 / 203	8.88 / 226	23 / 584	2.19 / 56	6.25 / 159	6.50 / 165	2.88 / 73	6.50 / 165	70 / 32
3	13.75 / 349	18.75 / 476	8.00 / 203	12.00 / 305	27 / 686	2.31 / 59	6.38 / 162	7.00 / 118	3.13 / 80	7.38 / 187	95 / 43
4	17.50 / 445	20.00 / 508	10.75 / 273	10.69 / 272	30 / 762	2.38 / 60	7.75 / 197	10.00 / 254	3.88 / 99	9.75 / 248	139 / 63
6	19.88 / 505	28.25 / 718	10.75 / 273	18.31 / 465	46 / 1168	2.19 / 56	7.88 / 200	10.00 / 254	5.00 / 127	11.00 / 279	250 / 1134

### Cv Factors\*

Size	Value
1"	23
2"	72
2-1/2"	135
3"	170
4"	350
6"	880

\* For water with clean, perforated basket

### Basket & Screen Effective Area - Tefzel®-Coated Basket

Pipe Size (in)	Perf. Size (in)	Pipe Area (in²)	Screen Area (in²)	Free Area (in²)	Free/Pipe Ratio
1"	1/32	0.86	19.5	5.2	6.1
2"	1/16	3.35	50.9	15.8	4.7
2-1/2"	1/16	4.78	80.2	24.9	5.2
3"	5/32	7.39	114.5	72.1	9.8
4"	5/32	12.73	168.3	106.0	8.3
6"	5/32	28.90	324.2	204.2	7.1

**Eaton North America – HQ**  
44 Apple Street,  
Tinton Falls, NJ 07724  
Toll Free: 800 656-3344  
(North America only)

Voice: +1 732 212-4700  
Fax: 952 906-3706

**Eaton Brazil**  
Voice: +55 11 2465 8822

**Eaton China**  
Voice: +86-21 5200 0422

**Eaton Europe/Africa/Middle East**  
Voice: +49-2486-809-0

**Eaton Singapore**  
Voice: +65 6825 1668

©2013 Eaton Corporation. All Rights Reserved. All trademarks and registered trademarks are the property of their respective owners. Litho USA. All information and recommendations appearing in this brochure concerning the use of products described herein are based on tests believed to be reliable. However, it is the user's responsibility to determine the suitability for his own use of such products. Since the actual use by others is beyond our control, no guarantee, expressed or implied, is made by Eaton as to the effects of such use or the results to be obtained. Eaton assumes no liability arising out of the use by others of such products. Nor is the information herein to be construed as absolutely complete, since additional information may be necessary or desirable when particular or exceptional conditions or circumstances exist or because of applicable laws or government regulations.

For more information, e-mail us at [filtration@eaton.com](mailto:filtration@eaton.com)

Visit us online at [eaton.com/filtration](http://eaton.com/filtration) for a complete list of Eaton's filtration products.