

Model 72SJ

- Carbon Steel or Stainless Steel
- Sizes 1" to 8"
- Flanged

FEATURES

- NPT steam connections
- Up to 100 psi steam pressure
- Quick open cover—no tools required
- Large capacity basket
- Threaded drain plug
- Machined basket seat
- Viton® seals
- Perforated or mesh 316 stainless steel basket

OPTIONS

- Basket perforations from 1/32" to 1/2"
- Basket mesh from 20 to 400
- Monel baskets
- Vent valves
- Drain valves
- Gauge/vent taps - 1/4" NPT
- Pressure differential gauge and switches



The Model 72SJ is for applications in which materials must be kept hot to remain fluid. Examples are chocolate, asphalt, resins, and polymers. By circulating steam or a heat transfer fluid through the strainer jacket, the strainer body temperature remains constant.

The basic strainer used in the Model 72SJ is Eaton's popular Model 72 simplex basket strainer that has proven itself an industry standard. All of the features of the Model 72 have been retained, including large basket capacity with a free straining area and a perforated

basket approximately six times the cross sectional pipe area. No tools are needed to open the cover. The quick opening, swinging yoke can be disassembled and the basket removed in seconds. The standard cover seal is Viton® and can be used in most applications up to a temperature of 400 °F.

Equipped with either a carbon steel or stainless steel jacket welded to the cast body, the steam jacket will handle steam pressures up to 100 psi.



Powering Business Worldwide

MODEL 72SJ Steam Jacketed Basket Strainer

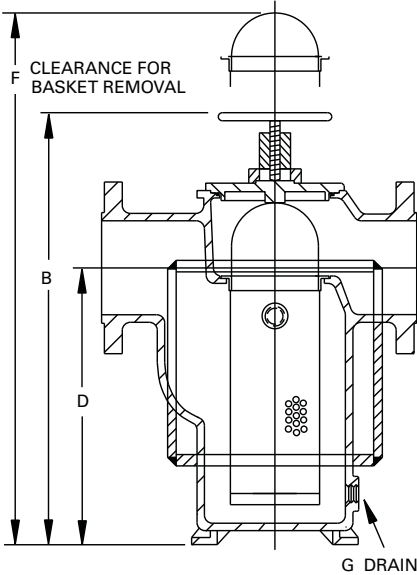
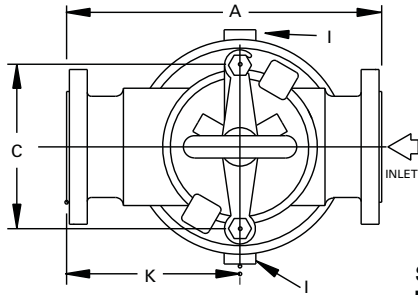
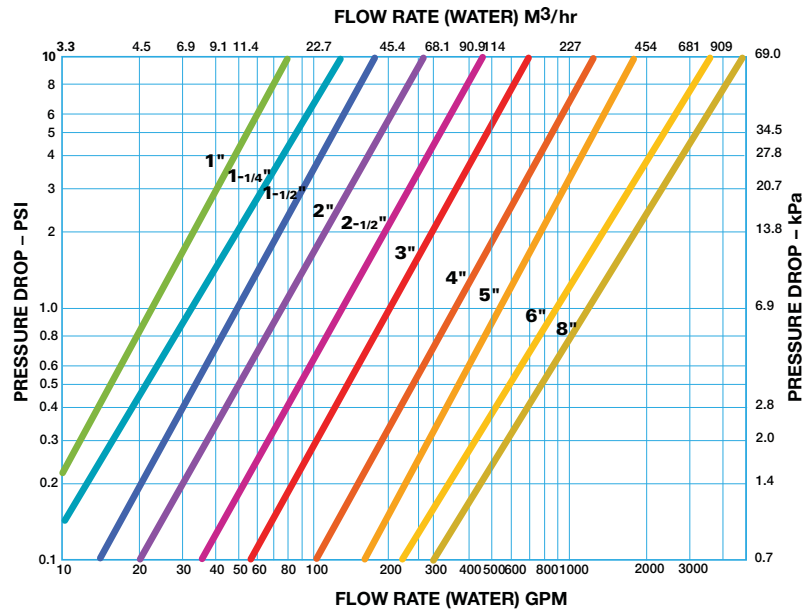

Selection Chart

Size	Material	End Connections	Seals	Pressure Rating
1" to 8"	Carbon Steel	Flanged 150#	Viton®	200 psi @ 100 °F
1" to 8"	Stainless Steel	Flanged 150#	Viton®	200 psi @ 100 °F

Cv Factors*

Size	Value	Size	Value
1"	22.5	3"	180
1-1/4"	31.5	4"	350
1-1/2"	46.0	6"	900
2"	73.0	8"	1400
2-1/2"	125		

* For water with clean, perforated basket

Dimensions (in/mm) Model 72SJ Straight Flow

Size	A	B	C	D	F	G	I	K	Net Wt (lb / kg)	
									Carbon Steel	Stainless
1	7.63 / 194	8.38 / 213	4.00 / 102	5.00 / 127	12 / 305	1/2	1/2	4.31 / 110	16 / 7	-
1-1/2	10.25 / 260	11.00 / 279	4.88 / 124	7.00 / 178	16 / 406	3/4	1/2	5.75 / 146	25 / 12	-
2	10.50 / 268	13.75 / 349	6.75 / 172	7.63 / 194	20 / 508	3/8	1/2	5.75 / 146	48 / 22	45 / 20
2-1/2	11.63 / 295	15.63 / 397	8.00 / 203	8.75 / 222	23 / 584	3/8	1/2	6.38 / 162	81 / 37	75 / 34
3	13.13 / 334	18.75 / 476	8.00 / 203	12.00 / 305	27 / 686	1/2	1/2	7.25 / 184	112 / 51	105 / 48
4	17.25 / 438	19.88 / 505	10.75 / 273	10.75 / 273	29 / 737	1/2	3/4	9.63 / 245	165 / 75	155 / 70
6	19.63 / 499	28.50 / 724	10.75 / 273	18.38 / 467	46 / 1168	1/2	3/4	10.81 / 275	315 / 143	280 / 127
8	27.00 / 686	40.50 / 1029	-	27.00 / 686	60 / 1524	1/2	3/4	15.75 / 400	653 / 297	653 / 297

Dimensions and weights are for reference only. Contact Eaton for certified drawings.

Eaton
North America – HQ
 44 Apple Street,
 Tinton Falls, NJ 07724
 Toll Free: 800 656-3344
 (North America only)
 Voice: +1 732 212-4700
 Fax: 952 906-3706

Eaton Brazil
 Voice: +55 11 2465 8822

Eaton China
 Voice: +86-21 5200 0422

Eaton Europe/Africa/Middle East
 Voice: +49-2486-809-0

Eaton Singapore
 Voice: +65 6825 1668

©2013 Eaton Corporation. All Rights Reserved. All trademarks and registered trademarks are the property of their respective owners. Litho USA. All information and recommendations appearing in this brochure concerning the use of products described herein are based on tests believed to be reliable. However, it is the user's responsibility to determine the suitability for his own use of such products. Since the actual use by others is beyond our control, no guarantee, expressed or implied, is made by Eaton as to the effects of such use or the results to be obtained. Eaton assumes no liability arising out of the use by others of such products. Nor is the information herein to be construed as absolutely complete, since additional information may be necessary or desirable when particular or exceptional conditions or circumstances exist or because of applicable laws or government regulations.

For more information, e-mail us at filtration@eaton.com

Visit us online at eaton.com/filtration for a complete list of Eaton's filtration products.